

CXB Series

LED High Bay Luminaire - 16" Round

Product Description

The CXB LED High-Bay luminaire delivers 23,000 lumens in distributions designed for general floor lighting. With exceptional lifetimes rated up to 75,000 hours, zero-restrike time and a compact, lightweight construction, the CXB Series is a direct replacement for incumbent HID and MH high-bay light sources that provides additional benefits of energy savings, enhanced safety and significantly reduced relamp maintenance costs.

Performance Summary

Delivered Light Output: 23,000 lumens
Input Power: 230 watts
CRI: 70
CCT: 4000K
Input Voltage: 120-277 VAC
Warranty: 10 years*
Lifetime: Designed to last up to 75,000 hours at 40°C
Mounting: J-box, pendant, hook and cord
Weight: Maximum 14 lbs

Electrical System

- Integral, high-efficiency driver and power supply.
- **Power Factor** > 0.9 nominal
- **Input Voltage:** 120V-277V, 60Hz

CXB

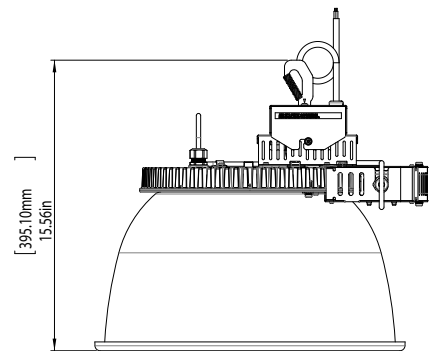
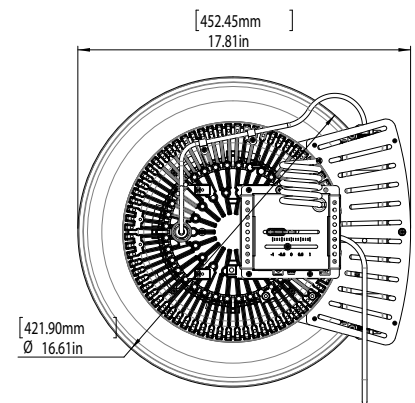

Accessories

- SC-5**
5' Galvanized Safety Cable
- SC-10**
10' Galvanized Safety Cable

Ordering Information - Reflector

(Light Engine must be ordered separately.)

- CXB-A-16**
CXB-A-16 = 16" Matte Spun Aluminum

Ordering Information - Light Engine

(Reflector must be ordered separately.)

Examples: CXB-23L-40K-U-1-HC
CXB-A-16

Product	Lumen Output	Color Temp	Voltage	Driver Mount	Mountings
CXB	23L 23L = 23,000 Lumens - 100 LPW	40K 40K = 4000 Kelvin	U U = 120-277 VAC	1 1 = Single Side Mount	HC HC = Hook and Cord JP JP = J-Box or Pendant Mount

*See www.cree.com/lighting for warranty terms.

US: www.cree.com/lighting T (800) 236-6800 F (262) 504-5415

Canada: www.cree.com/canada T (800) 473-1234 F (800) 890-7507

Rev. Date 1/7/2014

CXB Series

Product Specifications

CONSTRUCTION & MATERIALS

- Die-cast aluminum heatsink
- Low-profile, lightweight design provides ease of installation
- Mounting choices of direct j-box/pendant and hook & cord
- JP Mount mounts directly over existing 4" single gang square, rectangular and octagonal junction boxes for direct mount
- JP Mount has provision to accept 3/4" IP pendant (by others)
- HC Mount is provided with spring lock hook for mounting and factory installed 6' power cord; plug by others

OPTICAL SYSTEM

- 16" Anodized Matte Aluminum reflector
- Anodized Matte Aluminum reflector provides maximum efficiency
- LED system delivers proper uniformity & spacing
- Tempered glass protects LEDs against dust and dirt

ELECTRICAL SYSTEM

- Input Voltage: 120-277V, 60Hz
- Power Factor > 0.9
- Total Harmonic Distortion: <20%
- Temperature rating: Designed to operate in temperatures 0°C- 50°C

REGULATORY & VOLUNTARY QUALIFICATIONS

- cULus listed
- Suitable for damp locations
- DLC qualified
- IP54 rated driver
- IP65 rated LED optics

Photometry

CXB

CXB-23L-40K-U / Based on DTC Report Test #: PL02493-001

Fixture photometry has been conducted by a NVLAP accredited testing laboratory in accordance with IESNA LM-79-08. IESNA LM-79-08 specifies the entire luminaire as the source resulting in a fixture efficiency of 100%.

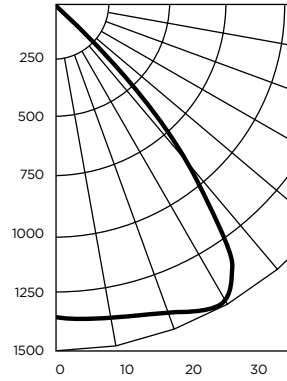

Projected Lumen Maintenance

Time	25,000 hours	50,000 hours	75,000 hours	100,000 hours
Lumen Maintenance Factor at 40°C ambient	0.94	0.88	0.84	0.79